

(SIDE PANEL REMOVED FOR CLARITY)

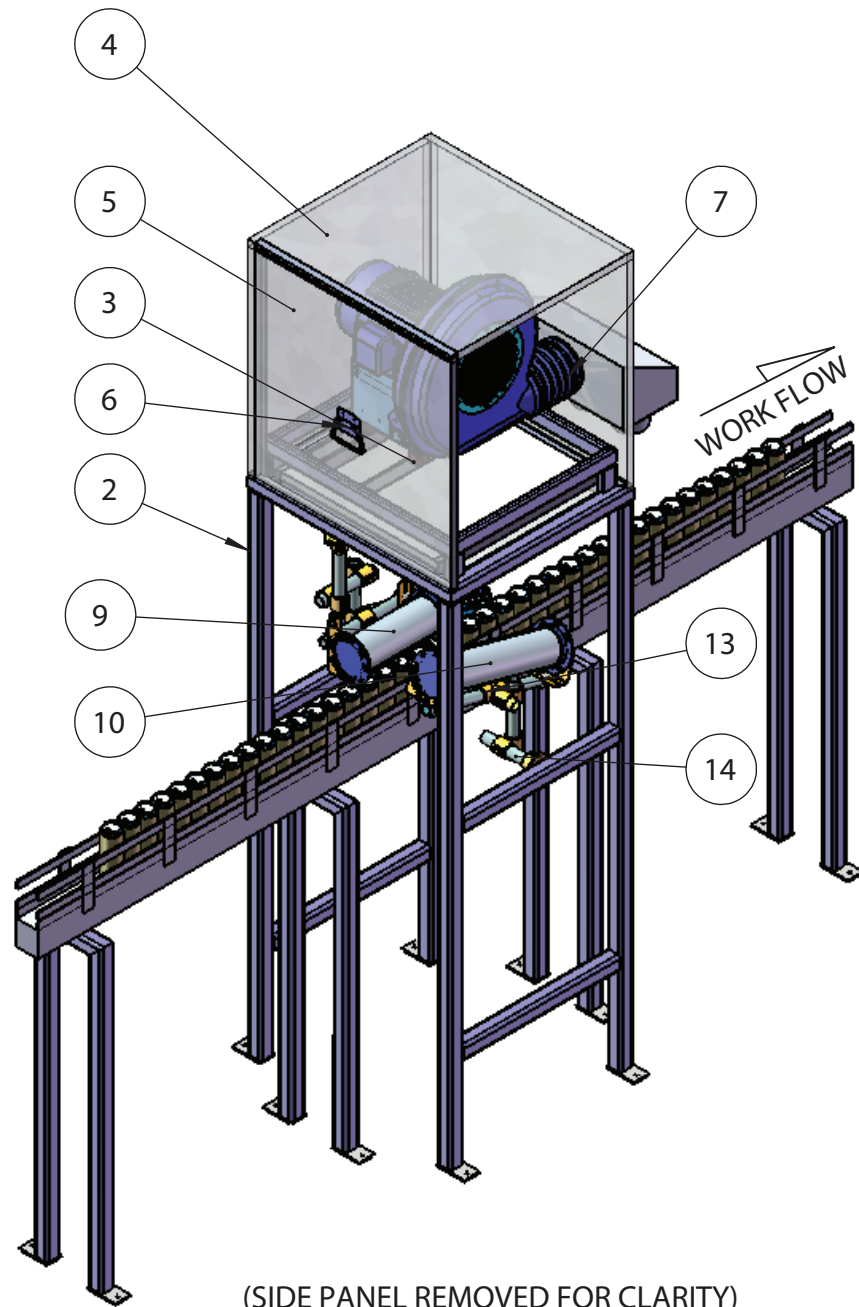

(SIDE PANEL REMOVED FOR CLARITY)

ITEM NO.	QTY.	DESCRIPTION
1	1	AF1 BLOWER ASSEMBLY MODEL# AF1-MEKA-05-36IC-CWBH
2	1	BLOWER ENCLOSURE BASE FRAME MODEL# CUSTOM-ME-05-CWBH
3	4	VIBRATION ISOLATORS - 1 3/8"
4	4	PERMANENT 20 GA. ACOUSTICALLY LINED PANEL
5	1	ACCESS DOOR 20 GA. ACOUSTICALLY LINED PANEL
6	1	ACCESS DOOR HANDLE
7	1	Ø 6" FLEX HOSE
8	1	DISTRIBUTION PLENUM - ATTACHED TO ENCLOSURE MODEL# TAP-CUST-06-4in x 3
9	1	AIR KNIFE MODEL# EF100-12
10	2	AIR KNIFE MODEL# EF100-18
11	3	Ø 1" WALL CLAMP MODEL# AF1-WC-4
12	7	Ø 1" CROSSOVER CLAMP MODEL# AF1-CC-4
13	2	Ø 1" SWIVEL CLAMP MODEL# AF1-SC-4
14	4	Ø 1" ALUMINUM PIPE - 10'
15	1	24"x24"x1" PANEL FILTER - R1

NOTES:

QTY: 1 REQ'D

MATERIAL: STAINLESS STEEL

SUPPORT LEGS: STAINLESS STEEL



Air Force 1 Blow Off Systems

phone: (519) 746-5035
www.af1.com

DRAWN BY:	AGL	DATE:	21-MAY-08
CHK BY:		DATE:	
ENG. APPR:		DATE:	
UNLESS OTHERWISE SPECIFIED: DIMENSIONS ARE IN INCHES TOLERANCES: FRACTIONAL ± 1/8" ANGULAR: MACH ± .5 BEND ± .01 TWO PLACE DECIMAL ± .01 THREE PLACE DECIMAL ± .001 FOUR PLACE DECIMAL ± .0005 INTERPRET GEOMETRIC TOLERANCING PER: ASME Y14.5M-1994			
PROPRIETARY AND CONFIDENTIAL THE INFORMATION CONTAINED IN THIS DRAWING IS THE SOLE PROPERTY OF AIR FORCE 1 BLOW OFF SYSTEMS. ANY REPRODUCTION IN WHOLE OR IN PART WITHOUT THE WRITTEN PERMISSION OF AIR FORCE 1 BLOW OFF SYSTEMS IS PROHIBITED.			

1	MATERIAL NOTE UPDATED - EVERYTHING STAINLESS	28-MAY-08	AGL	
0	RELEASED FOR CONSTRUCTION	20-MAY-08	AGL	
No.	REVISION	DATE	BY	
CAD FILE NAME: 08-18345-002		SIZE:	B SIZE	

DRAWING TITLE: BEVERAGE SYSTEM CAN BLOW OFF SYSTEM LAYOUT DETAILS - BOM	
CUSTOMER:	
SCALE: 1:20	08-18345-002
SHEET 1 OF 1	REV: 1